

**FEATURES**

- LonWorks® FTT-10A Free Topology to Multi-mode fiber
- Transparent repeater function
- Optical signal regeneration
- LED signal indication
- One or two fiber optic channels
- Supports ring, bus and point to point topology

**APPLICATIONS**

- Twisted pair to fiber optic communications
- Transparent signal repeater
- Electrical noise immunity
- Extends network up to 2.5K
- Optical signal regeneration

**DESCRIPTION & OPERATION**

The LNFR is a LON twisted pair to fiber optic repeater which is transparent to the network. Designed for TP/FT-10 78kbps LonWorks® networks to be connected via a fiber optic link. The LNFR allows multiple free topology networks to be connected over greater distances, or through electrically noisy environments. The LNFR is completely transparent to the network, and requires no software configuration or network addressing.

The LNFR is powered by 24VAC/DC supply. Network communication is received via an Echelon® FTT-10A twisted pair transceiver and translated to and from TTL signals for fiber optic transmission. Transmit and receive channels are carried on separate multi-mode fibers. The LNFR operates as a transparent repeater only, which does not perform any additional routing functions and requires no additional software configuration. LED indication is provided on all transmit and receive fiber channels. The FTT-10A transceiver does have some delay in its LON to TTL conversion, limiting the number of conversions to four (see application 2) you can have 4 sets of LNFRs on the same LON trunk provided the LNFR-D and connected to the main LON trunk.

The LNFR is available as a single or dual channel repeater. The single channel LNFR is used for simple point to point repeating functions. The dual channel LNFR transmits an incoming packet from the twisted pair to both fiber channels simultaneously, as well as echoing any incoming fiber signal on the other fiber channel. This allows the dual channel LNFR to support Ring, Bus, and point to point topologies.

**SPECIFICATIONS**

Size:	4"W x 3"L x 1.5"H
Mounting:	PVC plastic enclosure
Power:	24VAC 50/60 Hz
Communication:	Echelon® Free Topology FTT-10 To Multi-Mode Fiber Echelon LonTalk® Protocol
Lon Trunk:	18 AWG twisted pair
Fiber Cable:	Two 62.5/ 125µm diameter Multi-mode cable
Connections:	Terminal Block (twisted pair) ST® port (fiber optic)
Ambient Temp:	-20 to 80°C

**ORDERING INFORMATION****LNFR /X**

└ S - Single, or D - Dual fiber outputs

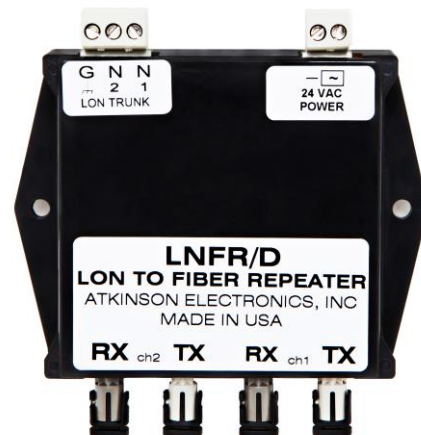

**PHYSICAL CONFIGURATION – SINGLE OUTPUT**

**PHYSICAL CONFIGURATION – DUAL OUTPUT**

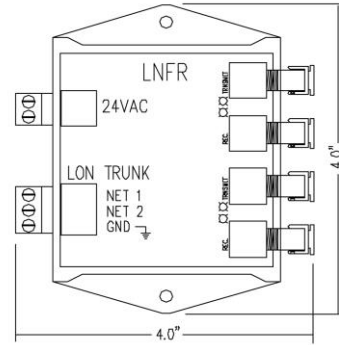
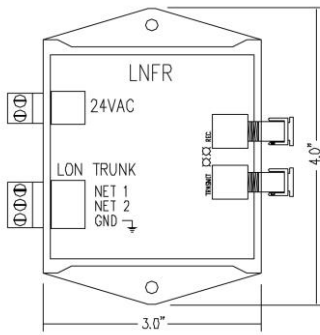

**APPLICATION 1  
NETWORK COMMUNICATION BETWEEN BUILDINGS VIA FIBER OPTIC CABLE**

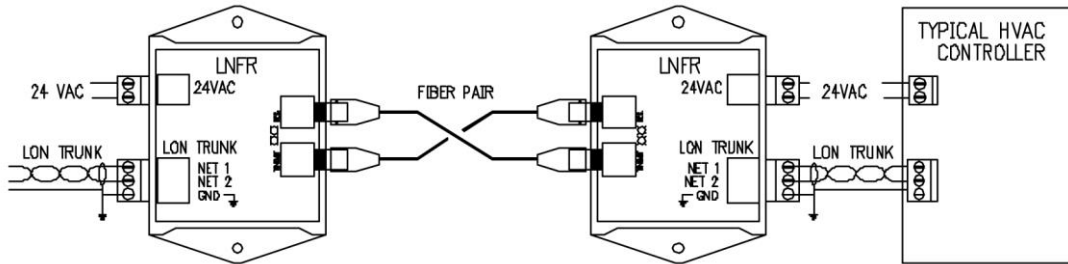

The LNFR single channel fiber repeater is used in a point to point application to extend the physical twisted pair network up to 2.5 km. The LNFR acts as a repeater only, and is completely transparent to the network. Any communication received on the near side of the free topology network will be propagated to the far side via fiber optic cable, where the twisted pair signal will be regenerated on the far side of the network.

**APPLICATION 2  
NETWORK COMMUNICATION BETWEEN BUILDINGS VIA FIBER OPTIC CABLE**

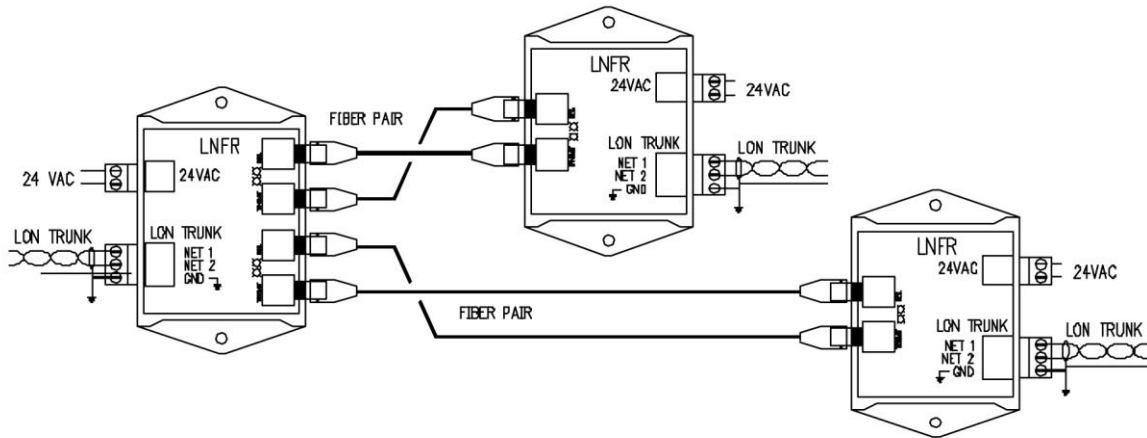

The LNFR-D (2 channel) repeater can be used to support ring and bus topologies. The incoming twisted pair communications are reproduced on both fiber channels. In addition, any communication received on one fiber channel will be echoed to the second fiber channel, as well as re-transmitted on the twisted pair copper network. All fiber links remain completely transparent to the network. **You can connect up to 4 sets (1 LNFR-D, 2 LNFR-S in the above configuration) on the same LON trunk (the LON trunk connects to the LNFR-Ds) making an asterisk or star configuration.** This limits the number of signal conversions to four, thru only point to point. If the LNFR-Ds are connected in series or a chain configuration the LON controllers on either end will talk over each other causing communication pack errors.

**APPLICATION 3  
NETWORK COMMUNICATION BETWEEN MULTIPLE BUILDINGS VIA FIBER OPTIC CABLE**

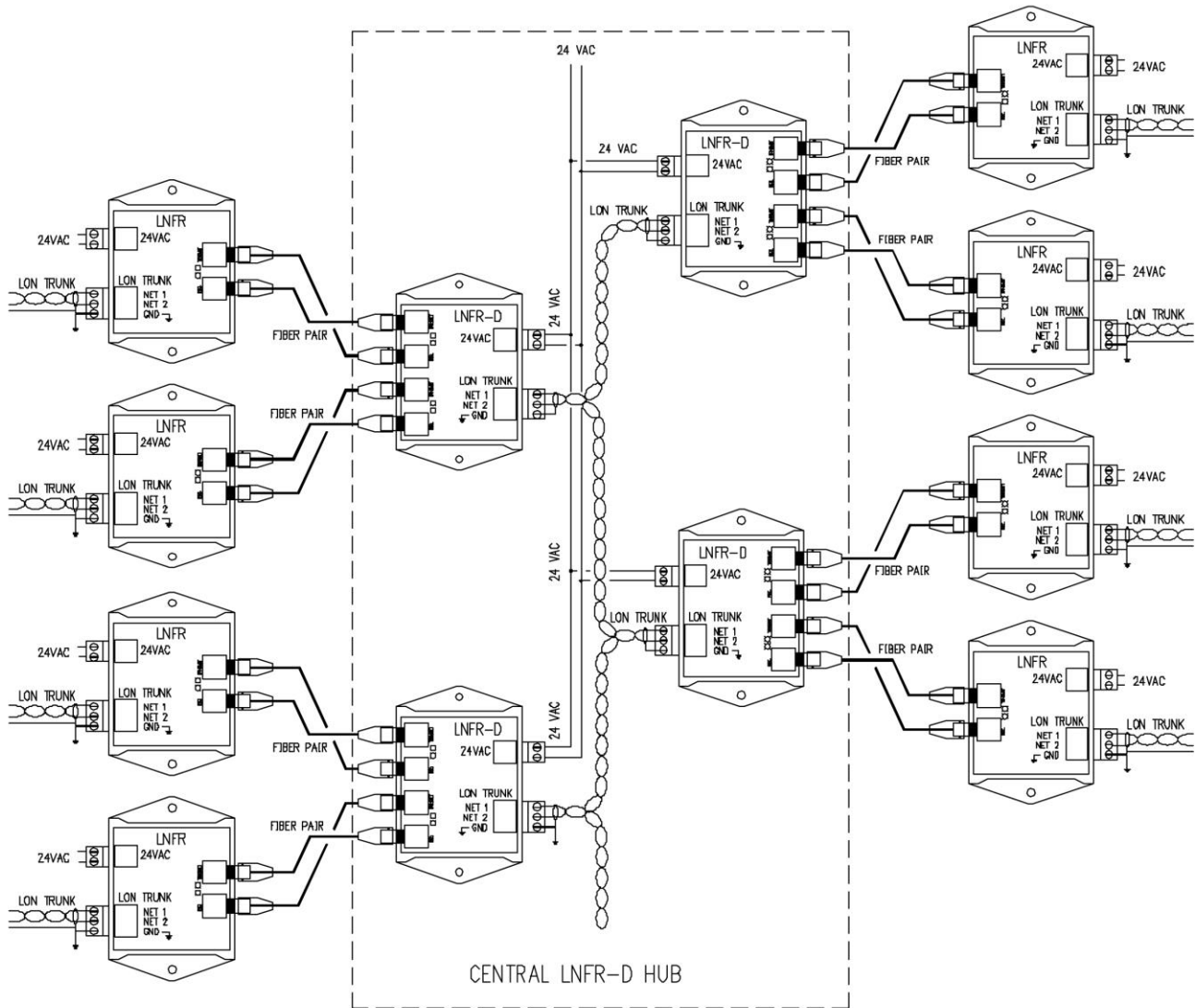

The LON communication platform is very unforgiving when it comes to transmission delays and congested trunks, the maximum number of LON control devices (total number of controllers connected to the LNFR-Ss and the main LON trunk) is about 64. The FTT10A transceiver converts the controller's processor TTL signals to LON or LON back to TTL for the processor. There is a delay generated each time the communication packet goes thru a FTT10A transceiver, so this limits the number of conversions to 6 as shown above (controller to LNFR-S to LNFR-D to LNFR-D to LNFR-S to controller). From the Jace to the controller it is 4 conversions.

The LNFR-D (2 channel) repeater is placed on the main LON trunk with the Jace front end, and the fiber runs then star out to the various buildings or locations to the LNFR-S which provides the LON trunk for that building or location. Standard end of line terminators are used at the LNFR-S and the last LON controller on the trunk.

If more than 64 devices will be sharing the LON trunk, it is recommended that on those buildings or locations where the majority of controllers are located, a router be used to limit only the LON traffic that must be communicated back to the Jace or other devices on the main LON trunk be allowed to pass to the LNFR-S. Failure to limit the amount of controllers and the band width they consume will cause communication problems on the LON trunk, controllers talking over other controllers, causing communication pack errors.